

# Operation Manual of New Multifunctional Oil Heating Rotary Thermal Transfer Machine

Model: MTX - 68

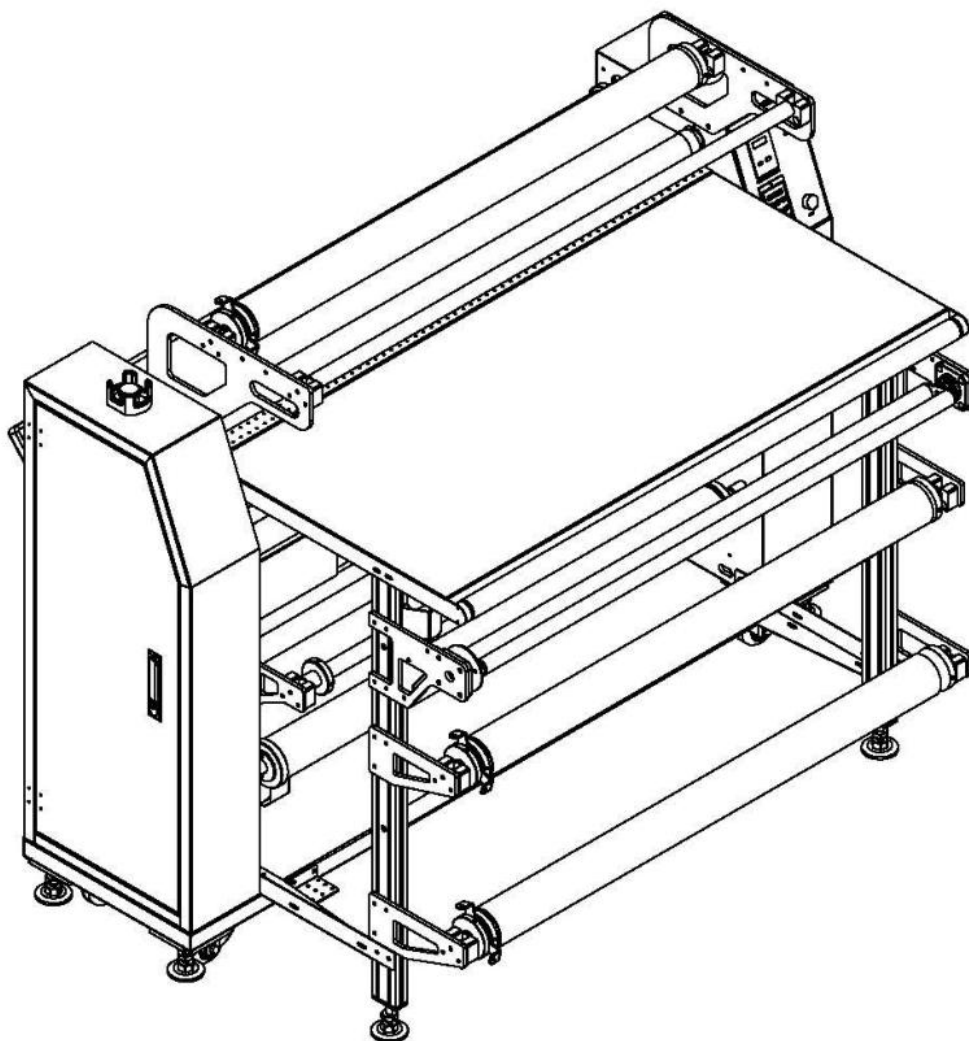

# Contents

I. Preface .....	3
II. Machine Introduction .....	3
III. Machine Parameters.....	4
IV. Installation .....	4
V. Machine Explosion View .....	5
VI. Machine Dimensions and Overview.....	6
VII. Function .....	7
VIII. Digital Controller Operation.....	9
IX. Operation .....	17
X. Attention .....	19
XI. Trouble Shooting.....	20
XII. Replace the Heating Tube.....	21
XIII. Daily Maintenance.....	21
XIV. Electrical Control Diagram.....	22
XV. Bill of Material.....	25

## I. Preface

1. Thanks for choose our New Multifunctional Oil Heating Rotary Thermal Transfer Machine.
2. This manual introduce the machine installation, operation, function settings, trouble shooting etc.
3. Incorrect installation and operation may cause machine damage or other accidents. So please read this manual before you start to use and make sure you are following the steps we suggest.
4. Daily and periodic maintenance is required. As the machine will be operated long time in the industrial working environment, the machine has potential fault due to the reason, including, but not limited to the room temperature, humidity, dust, bad operation, machine parts wear and deterioration,etc.
5. Any problems during the operation, please contact our sales department.

## II. Machine Introduction

Multi-functional Transfer Machine is developed to be the most advanced, practical and fully-featured transfer equipment, which is based on our traditional printing machine and combined with custom experience, international high tech models advantage, novel procedure of cotton cool heat transferring requirement. This machine can used to cutting pieces, roller transfer and cool transfer. At the same time, it owns merits of small space taking, labor saving and Lower power consumption.

From the whole manufacturing process, this equipment is adopted with CNC laser cutting process to ensure the assembly positioning accuracy and the accuracy of each axis parallel position, so that customers can get higher transferring quality and the blankets difficult deviation. Heating cylinder is equipped with double insulation design which brings better insulation than normal models. In the same cylinder diameter, the power consumptive lower than the rest of models by 30% -40%. This model

uses double manual pressure which can be adjusted and controlled separately. The rotational bearings are machining by CNC lathes processing technology with higher accuracy, diameter of  $\phi 87$ , bending deformation, so it improves the transfer quality.

From the transfer effect, this machine printing quality can achieve colorful and structured, the depth of penetration of the coloring effect which is similar to plain heat press results. At the same time, it can achieve higher efficiency with the kind of wide-format high-volume transfer.

From the machine operation, the cloth forwarding way of this model changes with three-put and three received design and gas spring roller of feeding and take-up,

which makes it possible to install and remove the roll material quickly. With this

improvement, customers can reduce labor and reducing the operator's labor intensity. If you are using cutting pieces of clothing transfer, up entering type makes cloth to position more accurately and reduce the defect rate.

### III. Machine parameters

Model: MTX-68

Machine size : 2300 mm (L) × 1313mm (W) × 1564mm (H)

Drum Width : 68 inch (1730mm)

Drum Diameter : 250 mm

Max. Speed : 0-1200 mm / min (Adjustable)

Nominal Voltage : 220V AC 50HZ three phase (or 380V AC 50HZ three phase)

Nominal Current : 37A (or 21A)

Nominal Capacity : 14 KW

Heating Mode: Oil Heated

Net Weight : 785KG (around)

Noise : 30 DB

Carton Dimension: 2480mm (L) × 1490mm (W) × 1830mm (H)

Note: The technical data is subject to the real equipment; Please understand the delay of data update If there is any difference.

### IV. Installation

1. When unpacking the machine package, please check whether the screws on the machine are loosened during the transit or not, if any screws are found loosened, please tightening the loosened screws immediately.
2. As this type of machine is relative heavy, it is suggested to put the machine on the horizontal ground floor with sufficient strength.
3. Being a kind of heat emitting equipment, this machine shall work in dry and ventilated places with no corrosive gases; flammable or explosive objects are strictly forbidden around the machine.
4. Warning - the machine shall be properly grounded prior to use in order to prevent any electric shock accidents.
5. Connect the power supply cables of suitable size corresponding to the rated power; please refer to circuit diagram.
6. Both the machine and work table shall be installed horizontally and connected firmly.

## V. Machine Explosion View

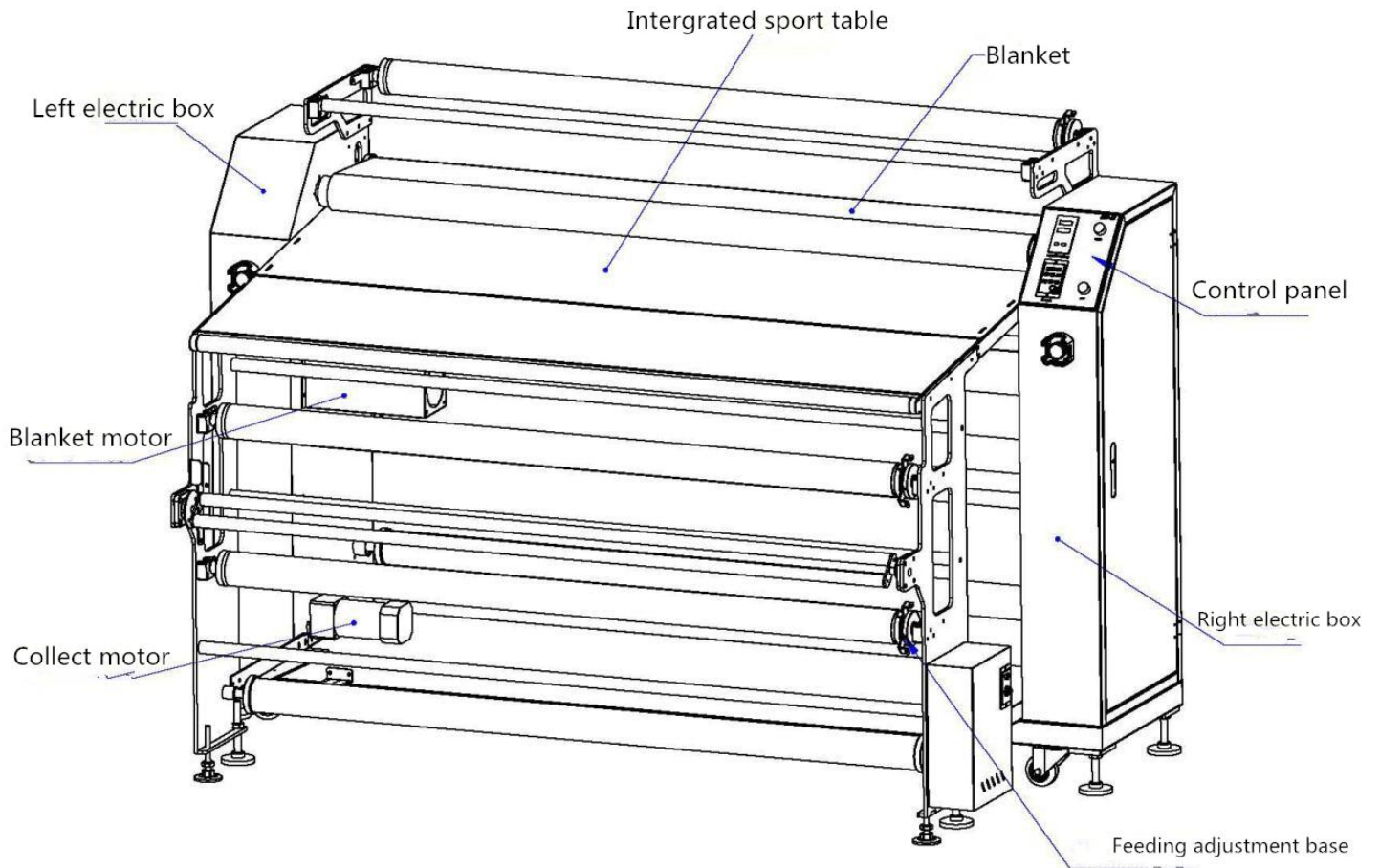

## VI. Machine Dimensions and Overview

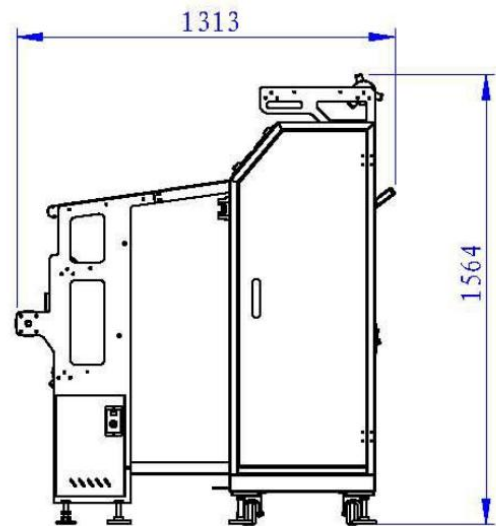
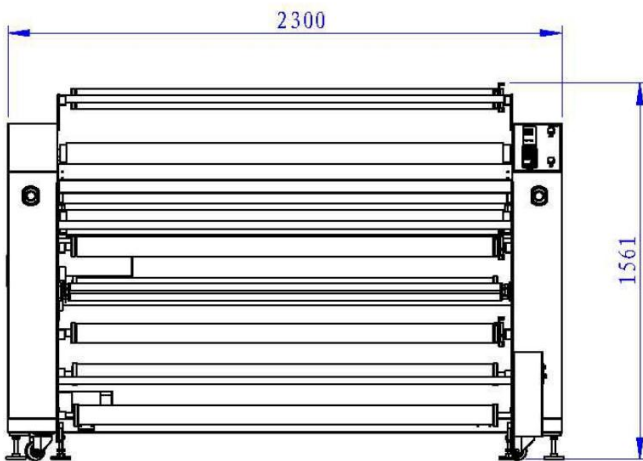
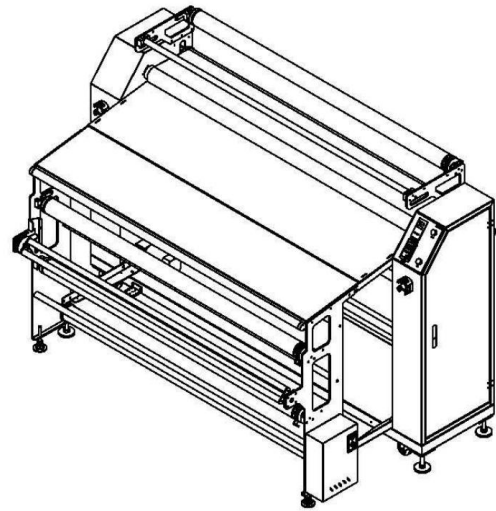
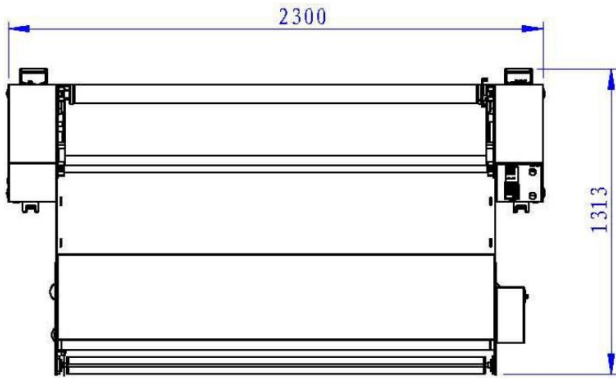

## VII. Function

### 1. Main electric box-back (right)

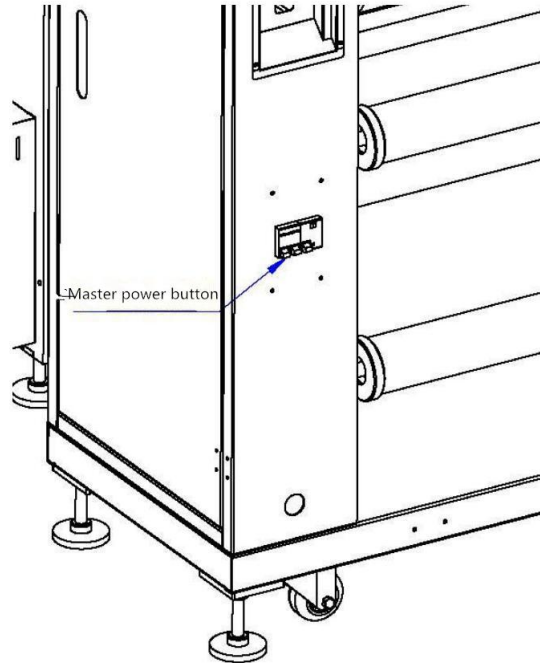

### 2. Main control panel (right)

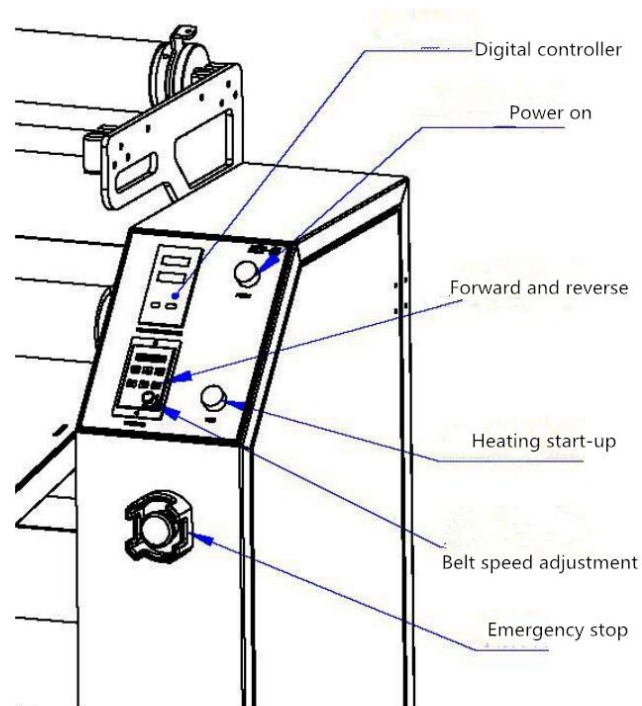

### 3. Secondary electric box- back (left)

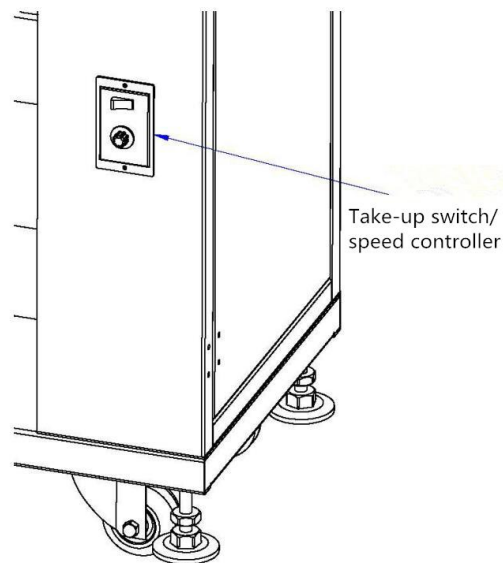

### 4. Left and right electric box--inside

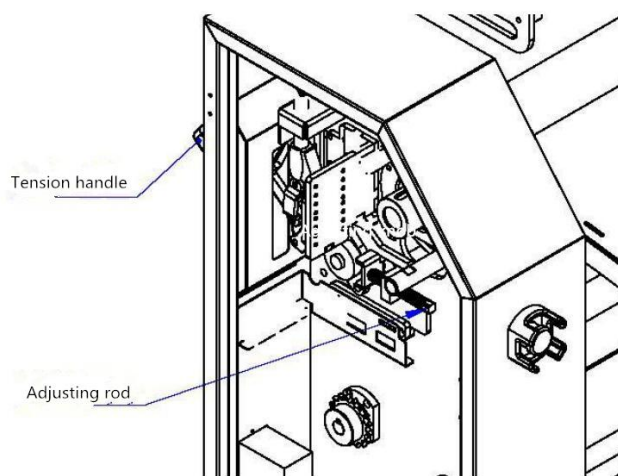

### 5. Working table-front (right)

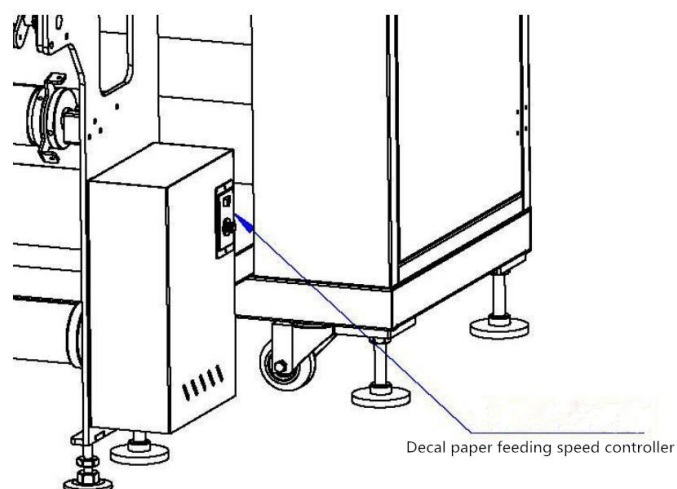



**Description:**

1. Main power button - please turn on the main power button before working.
2. Emergency stop button - stop all operation in emergency and reset after the trouble shooting.
3. Power on-the control system is connected when power on.
4. Temperature controller - to set and control the heating element temperature.
5. Forward and reverse button-to control the forward and reverse of the blanket.
6. Belt speed controller-to adjust the speed of belt for better transfer quality.
7. Heating buttons - control the heating power
8. Take-up mandrels speed controller-to control the power on-off and speed of the triaxial connecting unit back and downward.
9. Blanket tension adjust hand wheel - to control and adjust blanket pressure (push down) and tension (push up)
10. Adjusting rod-to adjust tension and position of blanket.

**VIII. Digital Controller Operation**

Before using this product, please carefully read the instructions for the proper use and proper preservation. (Please read the operating manual for the proper use of this product before using.)

**Wiring warning**

- To prevent instrument damage or failure, the choice of the appropriate fuse protected power cord and input / output lines to prevent the current impact.
- To prevent electric shock or instrument failure, power only after the completion of all the wiring work. Do not use near flammable gases.
- Fire, explosion or damage to the instrument, flammable, explosive gas, vapor emissions places. Do not modify the instrument.
- To prevent the accident or instrument failure, non-altered instrument.

**Summary**

REX-C□□□ Series Intelligent industrial accommodometer / temperature controller is dedicated microprocessor multifunction regulating instruments. It uses a switching power supply and surface mount technology (SMT), and thus the instrument is compact, reliable performance. Unique self-diagnostic function, the self-tuning function and intelligent control functions, so that the operator can get good results by a simple operation. Main features: Multiple thermocouple, RTD, analog signal free to enter, free to set the range, the software tune zero full-scale, cold end separate temperature measurement, auto-zeroing amplifier accuracy of better than 0.5% FS.

Fuzzy theory combined with conventional PID control fast and smooth, state-of-the-art setting program. Output optional: relay contact, logic level, SCR single-phase, three-phase over zero or phase shift trigger pulse, analog, attach Road definable alarm contact output.

## The main technical indicators

1. Measurement Precision:  $\pm 0.5\%FS$
2. Cold junction Compensation error:  $\pm 2^{\circ}C$  (0-50 $^{\circ}C$  within the software correction)
3. Resolution: 14bit
4. Power Supply: AC 85-265V 50Hz
5. Control Mode: industrial-grade expert self-tuning PID technology, compared with the traditional PID control with rapid temperature control, fast response, small overshoot, high precision control.
6. Insulation Resistance:  $>500m\Omega$  (500VDC)
7. Dielectric Strength: 1500VCA/min
8. Power Consumption:  $<10VA$
9. Occasions Environment: 0-50 $^{\circ}C$ , 30-85% RH non-corrosive gases

## Model defined selection

Model Identification

REX - C    -     -  \*    
                   ①          ②          ③          ④          ⑤          ⑥

① Meter Size (see Table 1)

② Control Mode

F: PID control and automatic speech inverse action

D: PID control automatically play a positive action

③ Input Type and Range (see Table 2)

④ Main Output

N: No output

M: Relay contact output

V: the voltage pulse output(SSR)

8: Current output

T: SCR zero output

G: SCR shift like pulse output

⑤ The First Channel Alarm Type (ALM1)

N: not set alarm

A: upper limit deviation alarm

B: lower limit deviation alarm

C: up and down significant deviation alarm

- D: range alarm
- E: with standby limit deviation alarm
- F: upper limit deviation alarm with standby
- G: lower limit deviation alarm with standby
- H: upper limit input value alarm
- J: lower limit input value alarm
- K: upper limit input alarm with standby
- L: lower limit input alarm with standby

⑥ Second Channel Alarm Type ALM2 (same as

Table1

Unit:mm

Model	Surface frame (W x H)	Shape (W x H x D)	Hole size (W x H)
REX-C100	48 x 48	44 x 44 x 100	(44+1) x (44+1)
REX-C400	48 x 96	44 x 92 x 100	(44+1) x (92+1)
REX-C700	72 x 72	68 x 68 x 100	(68+1) x (68+1)
REX-C900	96 x 96	92 x 92 x 100	(92+1) x (92+1)

Table 2 Input Scope Table

Thermo Couple	Input	Measure Scope	Code	Measure Scope	Code	Measure Scope	Code	
		0-200°C	K01	0-400°C	K02	0-600°C	K03	
	K	0-800°C	K04	0-1000°C	K05	0-1200°C	K06	
		0-1372°C	K07	0-100°C	K13	0-300°C	K14	
	J	0-200°C	J01	0-400°C	J02	0-600°C	J03	
		0-800°C	J04	0-1000°C	J05	0-1200°C	J06	
	R#1	0-1600°C	R01	0-1769°C	R02	0-1350°C	R03	
	S#1	0-1600°C	S01	0-1769°C	S02			
	B#1	400-1800°C	B01	0-1769°C	B02			
	E	0-800°C	E01	0-1000°C	E02			
	N	1-1300°C	N01	0-1300°C	N02			
	T#2	-199.9-400°C	T01	-199.9-400°C	T02	-199.9-200°C	T03	
		0-350°C	T04					
	Thermal Resistance	Pt100	-199.9-649.0°C	D01	-199.9-200.0°C	D02	-100-50°C	D03
			-100-100°C	D04	-100-200.0°C	D05	0.0-50.0°C	D06
0.0-100°C			D07	0.0-200.0°C	D08	0.0-300.0°C	D09	
0.0-500°C			D10					
	Cu50	-50.0-150°C	P01	0.0-150.0°C	P02	0.0-100.0°C	P03	
		0.0-50.0°C	P04	-50.0-100.0°C	P05	-50.0-50.0°C	P06	
		-50-150°C	P07	0-150°C	P08	0-100°C	P09	
		0-50°C	P10					
Standard	0-5VDC	0.0-100.0°C	401					

signal	1-5VDC	0.0-100.0°C	601				
	0-20Ma#3	0.0-100.0°C	701				
	4-20Ma#3	0.0-100.0°C	801				

#1 Can not guarantee the accuracy scope of 0-399°C.

#2 To ensure accuracy in the scope of -199-100°C.

#3 A resistor of 250 Ω is needed between the input terminal external

## Installation

### Precautions

1. Instrumentation installed in the following environments

\*Atmospheric Pressure: 86-106kpa

\*Ambient Humidity:0-50°C

\*Ambient temperature:45-85% RH

2. Installation should pay attention to the following circumstances

\*Drastic changes in the ambient humidity

\*may cause condensation

\*Corrosive,flammable gas

\*Direct vibration or shock theme structure

\*Water, oil, chemicals, smoke or steam pollution

\*Excessive dust, salt, or metal powders

\*Air conditioning blowing straight

\*Direct sunlight

\*The accumulation of heat radiation

### Installation Process

1. Panel cutout disk played a tho rectangular square hole to install the meter.

2. Multiple instrument installation, the distance between the left and right holes should be greater than 25mm,up and down two holes distance should be greater than 30 mm.

3. Embedded in the instrument panel cutout within.

4. Instrument mounting hole into the mounting bracker.

5. Pushed tight mounting bracker to the instrument with the disk is firmly bonded to tighten the screws.

## Wire Connection

### Wiring

(1) Thermocouple input, you should use the corresponding compensation wire.

(2) RTD input, you should use the same cross-sectional area of the low resistance, the same material, the same length of three wire.

(3) Input signal line should be away from the instrument power cord, power supply

and load lines to avoid noise.

(4) The instrument power cord is usually not the power supply line interference, such as interference noise filter must be used, and using a noise filter should note the following:

- 1) Shorten the power cord plug full twist pitch, the shorter the distance, the better.
- 2) Install a noise filter on the dashboard and grounded to minimize the short noise filter output terminals, the wiring distance
- 3) Do not install insurance, and switch the noise filter output. This will reduce the effect of the noise filter.

(5) The power is turned on after 5-6 seconds preparation time meter relay output external connection loop signal use, and with a time delay relay.

(6) Do not over tighten the terminal screws, use the appropriate terminal screw lug.

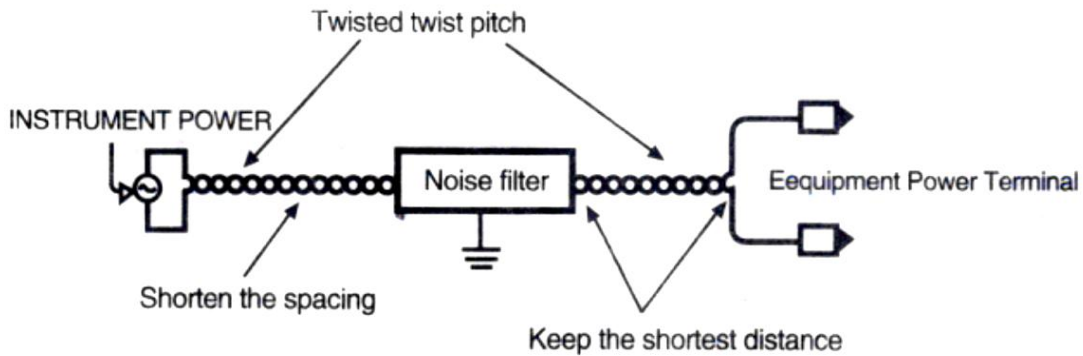

### Panel Name and Ministries Function

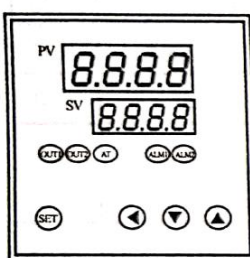

No	Panel Description	Content Description
1	PV	Measurement Value / Mode Display Value
2	SV	Settings / Mode Content Displayed Value
3	OUT1	Output 1 Indicator
4	OUT2	Output 2 Indicator
5	AT	PID Automatic Calculation Indicator
6	ALM1	Alarm 1 Indicator
7	ALM2	Alarm 2 Indicator
8	^	Increase the Key
9	V	Reduce the Key
10	<	Shift Key
11	SET	Set / Mode Key

### Operational Processes

**Boot Process**

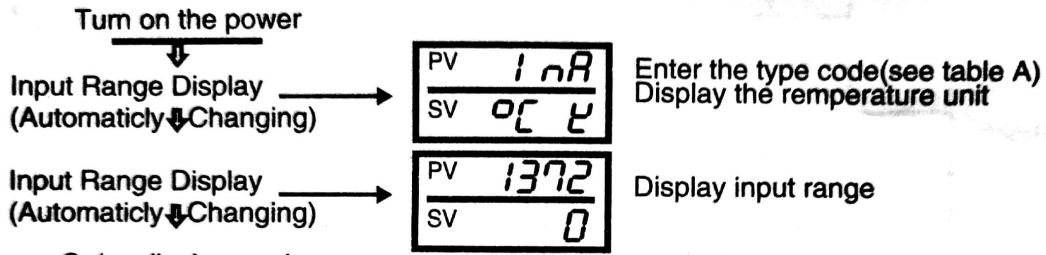

Sv/pv display mode

Table A

Display	P	J	R	S	B	E	N	T	Pt	CU	mV	mA	V
Input mode	Thermocouple(TC)								ThermocRedistance(RTD)		Voltage and Current		
	K	J	R	S	B	E	N	T	Pt100	Cu50	mV	mA	V

**Setting Mode:**

SV/PV normal display state, click the "SET" button, the SV display is flashing by pressing the "<" button, find the desired set temperature digits, and then click the "SET" button, the meter tum to the SV/PV Normal display state

**Parameter Setting Mode:**

This parameter is used to set the alarm, PID constants and other parameters. Normal display mode, press and hold the "SET "button for three seconds, the PV display shows the parameter setting mode, display the corresponding values in the "SV" display parameters in the following table, press the "SET" button to display symbols:

Note: display the reply teature native When the operator parameter setting modiry operation not to return to the main display mode, the instrument will return to the main display mode automatically after 30 seconds, the altered parameters are not saved. Meter read prior to use or modify the parameters, The following processes such as instrument no such function will not display this content.

Display Characte	Name	Specification	Setting Range	Factory Default
	PV/SV	Measured values/settings	Full scale	
RL1	AL1	The first set ot alarm	Full scale	
RL2	AL2	The second set ot alarm settings	Full scale	
RLB	ATU	Self-tuning When the temperature effect is not ideal to use it!!!	0:off auto-tuning 1:self-tuning	0
P	P	Proportional band(see*1)	0-full scale When set to 0 for position control	30
1	1	Integration time(sec)	0-3600 seconds When set to 0,no integral action	240

d	D	Derivative lime(seconds)	0-3600 seconds When set to 0,no derivative action	60
Rr	Ar	Reference values(see*2)	AT automatically set	25
r	T	Working period(seconds)	In proportion to the time period of 0-100 seconds	(see*3)
oH	OH	The main control does not work bandwidth	1-100 unit(PV)	2
SC	SC	Measurement error	-200-200 unit(PV)	0
LCA	LCK	Data lock(see*4)	0000-0111	0000

1: When  $\neq 0$  instrumentation or PID control, the need to rationalize the set values of the "I D", the first to open the "AT" self-tuning function, so that e control to achieve the best when P=OON/OFF control, must be set o control the value of the return difference "OH".

2: This is the PID internal reference values are not normally required to man-made. " AT" cones with the set will automatically set this value.

3: The relay contact output 20 seconds 2 seconds flip-flop output/gate flow control tube output voltage pulse output /thyristor control tube drive

4: Set data lock(LCK)function

Set data lock function is use to prevent some often set parameters Ukrainian operation, in the three forbidden lock state parameters for each level state ban lock parameter locked can not be set or changed but monitoring

1, When LCK=0000 , all parameters can be modified

2, When LCK =0001, the data can not be modified, except SV. ALL, AL2

3, When LCK=0011 all the data can not be modified, except SV

4,When LCK = 0111, all of the data can not be modified

Message	Sprecification	Exclusion Method
<i>Err</i>	Equipment Error	Please send overhaul
<i>0000</i>	Input the disconnection polarity reversed or exceeds the input range	Please check whether the input signal error
<i>UUUU</i>	Input the disconnection polarity reversed or exceeds the input range	Please check whether the input signal error

### The instrumentation technical parameters mode settings

After a normal power meter, according to the parameter setting mode to enter the ice to find data lock parameter"LCK"to code"1000",then press the "SET"button and the "two key while holding down for about 30 seconds PV display shows "GOD" = 0000 can be obtained, press the "SET" button and cycle through the following parameters:

Display Character	Settings				Specification	Scale Range
<i>SL 1</i>	0	0	0	0	K	0-1372℃
	0	0	0	1	J	0-1200℃

	0	0	1	0	R	0-1769℃
	0	0	1	1	S	0-1769℃
	0	1	0	0	B	0-1820℃
	0	1	0	1	E	0-800℃
	0	1	1	0	N	0-1300℃
	0	1	1	1	T	-200-400℃-199.9-400.0℃
	1	0	0	0	Pt100	-200-650℃-199.9-650.0℃
	1	0	0	1	cu50	-50-150℃-50.0-150.0℃
	1	0	1	0	0-400Ω	-1999℃-9999℃
	1	0	1	1	0-50mV	-1999℃-9999℃
	1	1	0	0	0-20mA	-1999℃-9999℃
	1	1	0	1	0-5V(0-10V)	-1999℃-9999℃
SL2	0	0	0	0	Slightly	
SL3	0	0	0	0	Slightly	
SL4	0	0	0	0	First alarm function is not set	
	0	0	0	1	Upper limit deviation alarm	Type selection of the first alarm (AL1)
	0	0	1	0	Upper / lower limit deviation alarm	
	0	0	1	1	Process value alarm	
	0	1	0	1	Lower limit deviation alarm	
	0	1	1	0	With alarm (alarm) region	
	0	1	1	1	Process value lower limit alarm	
	0	0	0	0	Standby alarm function	First alarm standby type selection
	1	0	0	0	Standby alarm function	
SL5	0	0	0	0	The second set of alarm function is set	First alarm standby type selection
SL6	0	0	0	0	Positive action control (cooling)	The main control forward / reverse action selection
	0	0	0	1	The inverse operation control (heating)	
	0	0	0	0	Master time proportional output	The main control output type selection
	0	0	0	1	Master continuous output (4-20mA)	
SL7	0	0	0	0	Incentive alarm	Incentive alarm / non-incentive alarm / the first alarm
	0	0	0	1	Non-incentive alarm	
	0	0	0	0	Incentive alarm	Incentive alarm / non-incentive alarm / the second alarm
	0	0	1	0	Non-incentive alarm	
SL8	0	0	0	0	Slightly	
SL9	0	0	0	0	Slightly	
SL10	0	0	0	0	Slightly	
SL11	0	0	0	0	Slightly	



When "COD" = 0001, press the "SET" button and cycle through the following parameters:

Display Character	Factory Default	Specification	Setting Range
SLH	Accordong to orders	Set the measuring range ipper limit	See above table
SLL	Accordong to orders	Set the measurement range limit	See above table
PCdf	0	Decimal places	0-3
oH	2 or 2.0	AT comes with no action given output bandwidth	0-100 or 0.0-100.0
AH1	2 or 2.0	The first alarm output is not active bandwidth	0-100 or 0.0-100.0
AH2	2 or 2.0	The second alarm output is not active bandwidth	0-100 or 0.0-100.0
df	1	Digital filter constant	0-100

Instrument maintenance and preservation instrument since the billing from the date eighteen months the internal factors manufacture quality failure by the company responsible for the comprehensive warranty, Damage due to improper use of the company charge a repair cost of the company meter lifelong maintenance, Instrumentation in complete packaging stored in dry and ventilated place non-corrosive gases.

## IX. Operation

1. Make sure that the body is well grounded and the power switch on the outside is correct (the neutral wire is connected to the N terminal);
2. Adjust the tension handles in the left/right electrical box separately, and push the handle (can be extended) Let the blanket be properly tensioned, but not too tight, in case it does not extend in parallel
3. Push the main switch on the right chassis and press the "POWER" button.
4. Re-adjust the governor knob to make the blanket Turn, clockwise to accelerate.
5. Confirm that the heating cylinder is rotating, then press the "HEAT" button to set the temperature to the appropriate number. (The factory setting is generally 200 °C)
6. When the temperature reaches the set value, wait for a few minutes to make sure that the temperature is stabilized. Test the transferred result with a small piece of material.
7. Place the paper and lining (separation) paper on the correct rollers, feed the lining paper into the drum, and then send the printing paper and cloth to the drum.

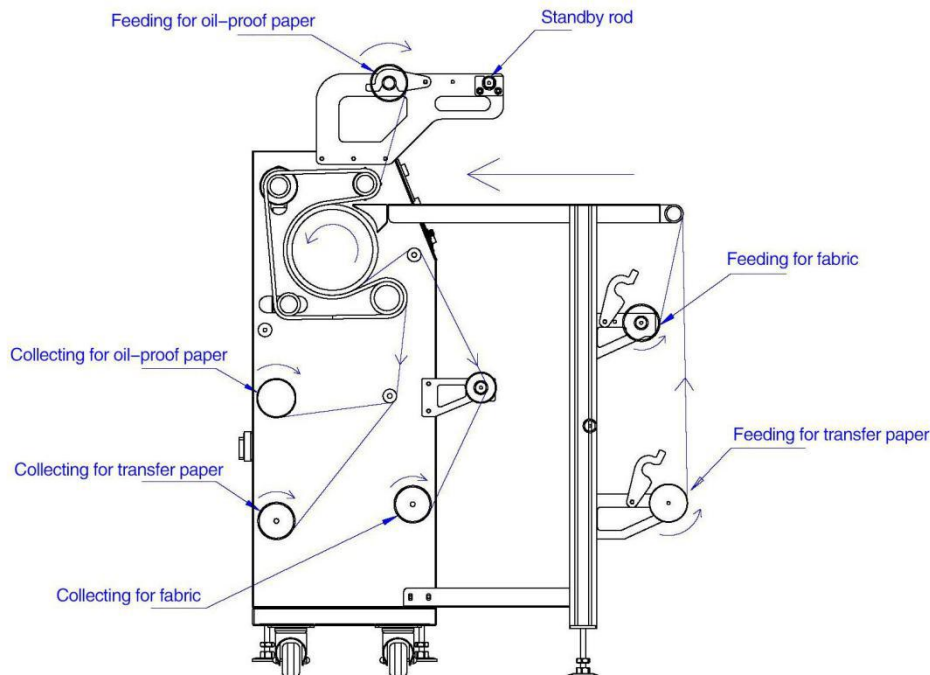

Take the roll-to-roll transfer as an example:

- (1) . Put the roll to be printed.
- (2) . Put in the transfer roll paper, the pattern surface is attached to the cloth.
- (3) . Put the roll paper, Between the transfer and the blanket to prevent soiling of the blanket.
8. When the liner is turned out of the main unit, wrap it around the reel on the back of the main unit and adjust the speed to automatically wind it up.
9. The transfer paper is wound around the reel on the front of the main unit. The speed of the paper roll can be adjusted by the controller behind the left box of the main unit.
10. During the transfer process, the customer can adjust the speed up or down according to the color depth of the transferred pattern, and also adjust the running speed of the drum.
11. After the transfer work is finished, turn off the “HEAT” button, let the main unit rotate and cool, and then cool down to below 100 °C before turning off. The machine must be turned on by someone.



12. In case of special circumstances, please turn off the “POWER” and “HEAT” at the same time. The machine will cooling down automatically. After running for a certain period of time (generally set to 2 hours), it will shut down automatically.



13. In the event of a power outage, or when the emergency stop switch is pressed due to special circumstances, immediately turn the handwheel on the back of the right chassis to remove the blanket from the drum, and take out the transfer if the machine is in a high temperature state. In the meanwhile, place a heat-resistant material between the blanket and the drum to prevent the blanket from damage.

## X. Attention

1. Because the tension at both ends of the felt is inconsistent, the blanket will be deflected to the left or right, so there is a belt with a deviation adjustment roller inside the machine. If the blanket is offset to the right, tighten the right end blanket; if the blanket is offset to the left, tighten the left end of the blanket. Specific steps: Insert the special wrench that is dispensed into the end of the adjustment screw. Note that the clockwise is for relaxation and the counterclockwise for tension. Tape adjustment can be done in a short time, so be patient.
2. Because it is a thermal machine, during the use, the shaft stick or the heating

element and the size bearing may make some noise due to the thermal expansion relationship. It is a normal phenomenon and does not have to panic.

3. On the control circuit board and the inverter inside the chassis, it should be kept clean and free of metal and conductive objects such as dust. The collector ring carbon brush cover should not be opened at will, be careful of electric shock.

4. If you need to replace the heating element, reducer, lubricating oil, etc., you must use the company's special model, and you must not change or replace it.

5. The external surface of the heating cylinder must not be corroded with corrosive liquid and hard objects entering and scratching. The coating peeling off is not covered by the warranty.

6. The main carpet is a valuable component. Please make sure that the switch is on duty to prevent burnout. This component is not covered by the warranty.

## XI. Trouble Shooting

Fault phenomenon	cause of issue	Method of exclusion
Temperature cannot be added	①The collector ring is in poor contact with the carbon brush	①Use fine sandpaper to remove carbon deposits and install them in an anastomosis
	②Missing phase - that is, the incoming line or the main line is detached or loose	②Check route
	③One or more sets of heating tubes burn out or the terminals are loose	③Replace the heating tube or tighten the wiring
	④The heating element is aging, (this is not possible with the new machine)	④replace the heating tube
	⑤Solid state relay is broken	⑤Replace
Temperature can't be controlled	①solid state relay breakdown	①Replace
	②The temperature controller is broken	②Replace
The cylinder does not turn	①The blanket is too loose	①Tighten the blanket
	②Sprocket slip	②Tighten the clamping screws
	③Bearing stuck	③Replace
	④Inverter failure or AC contactor failure	④Replace
	⑤Motor or reducer failure	⑤Replace
Display temperature float	①Temperature probe is broken	①
	②Contactor failure between carbon	②Grinded to the

	brush and slip ring	anastomosis with fine sandpaper
	③Motor or reducer failure	③Remove foreign matter
Master switch trip	①Electric heating tube aging or burning off	①Replace
	②Collector ring breakdown	①Replace the slip ring ②Replace the solid state relay

## XII. Replace the Heating Tube

- 1 Open the manhole at the right end of the machine.
- 2 Loosen the old heating tube and fix the power cord connection terminal.
- 3 Unscrew the heating tube.
- 4 Check if the new heating tube two-pole terminal is tightened.
- 5 Insert a new heating tube and check that the heating tube nut seal is intact and wrap the iron band.
- 6 Tighten the heating tube and connect the wires.
- 7 Replace the required heating tubes in sequence with the above steps.
- 8 After replacing all the heating tubes, check again that all nuts are tight.

## XIII. Daily Maintenance

1. Before using the machine, check whether the power supply is energized and the ground wire connection is normal.
2. Regularly check whether there is dust inside the machine, and wipe it off in time to keep every part clean.
3. Regularly check the roller and the inside of the blanket Whether it accidentally falls into metal or sundries, if abnormal conditions are found, it must be handled first.
4. Check the wiring connection regularly. If there is a spark, please replace the damaged parts in time.
5. Remove dust from the body casing and keep around. The environment is dry and not wet.
6. Check the periphery of the engine cover regularly. If other things are piled up, , clean it up and make sure the motor is cooled.
7. To ensure the normal operation of the bearing, please add high temperature lubricating oil(heat-resistance temperature is above 300 degrees) to all bearings once a week.
8. Don't press the emergency stop switch unless it's absolutely necessary. Don't hold the emergency stop switch for over 3 minutes even in emergent cases.

9. Check the electric wire and circuit frequently to find the aging problem in time
10. Always check the parts to make sure that lubricating oil is added to all bearings and joints.
11. Clean the machine every week.

### XIV. Electrical Control Diagram (220V three phase)

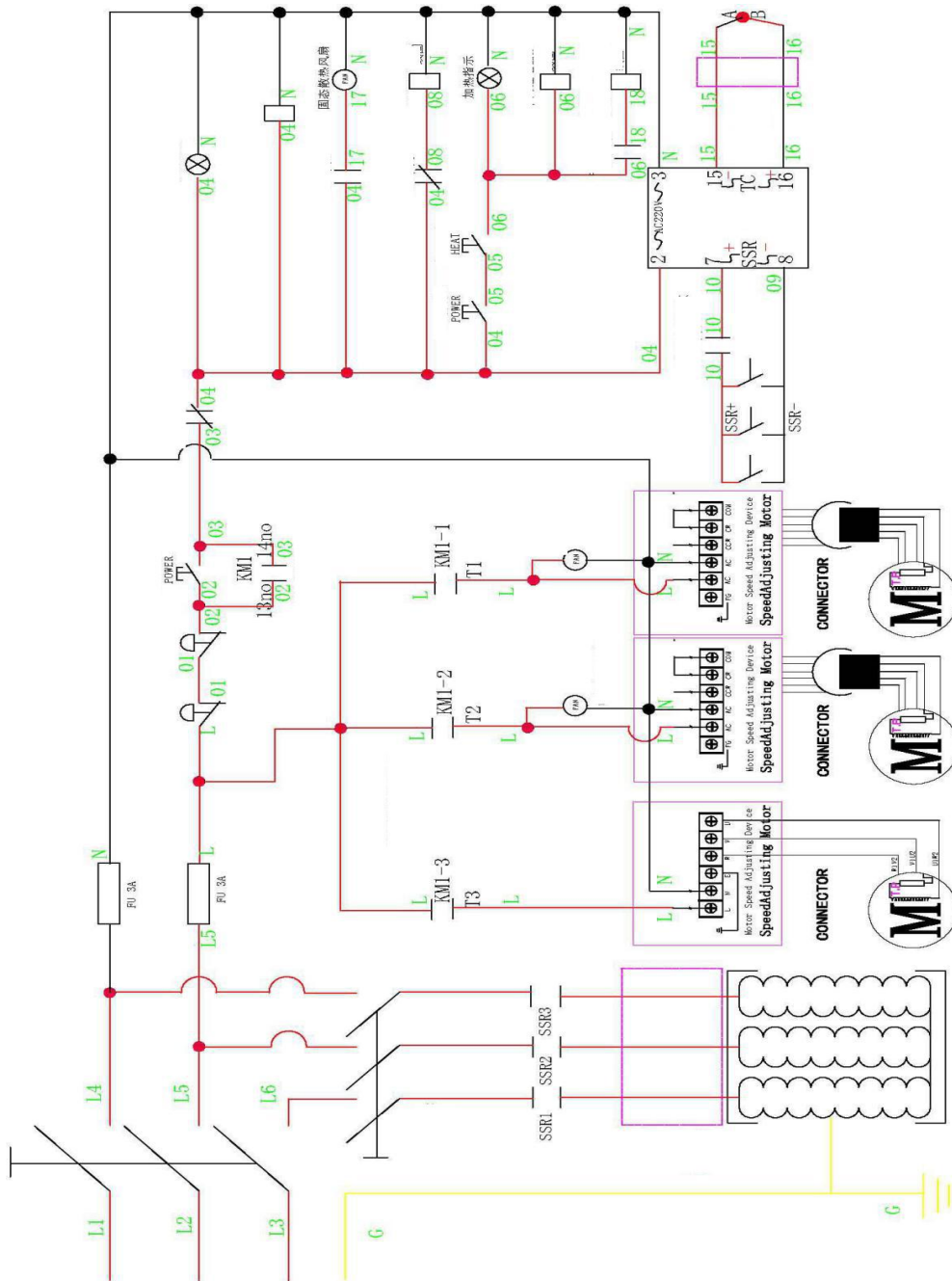

### Electrical Control Diagram (380V three phase)

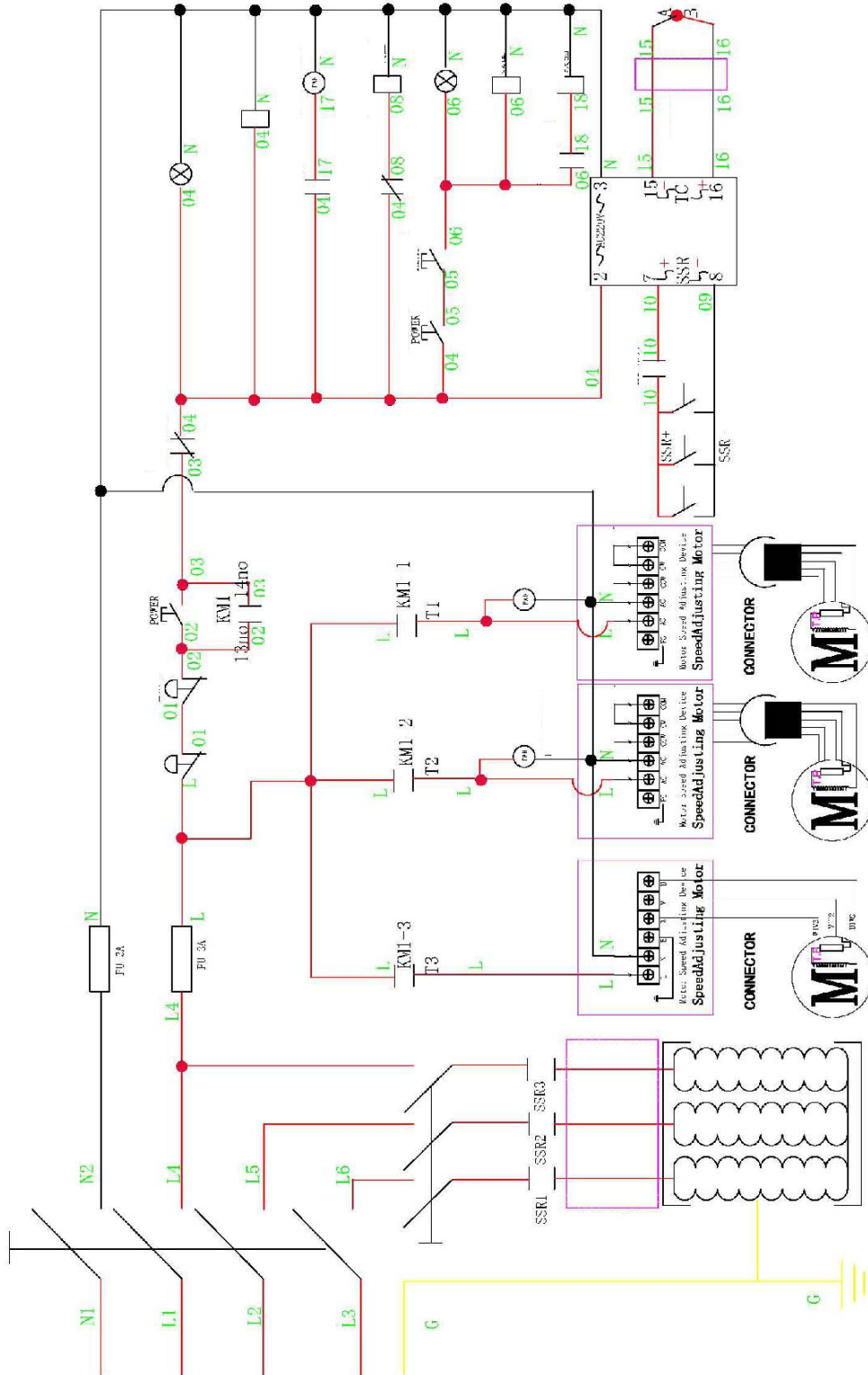

## MTX-68 inverter adjustment use and operation instructions

1) Turn on the power and press the power button. The temperature control table PV shows the actual temperature. SV shows the set temperature, the default is 200 degrees: the governor displays 0. The STOP indicator lights up. Click the RUN start button, the RUN green indicator lights up, and the machine is running.

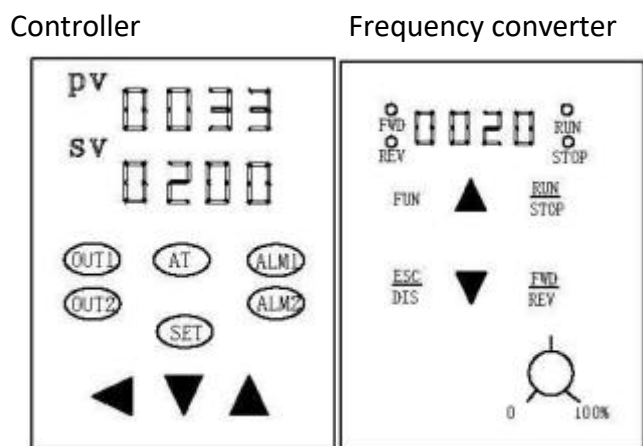

2) Click the SET button on the temperature control table, and the SV setting temperature value flashes. Press **Shift**. Press **▲▼** to increase or decrease the product setting value, press SET button to save and exit, set the completion point Heat switch to turn on the heating switch, and the machine enters the heating mode.

3). Click the inverter's FWD/REV button to switch between forward and reverse: adjust the inverter knob to adjust the transfer speed of the roller. 68 is recommended to use 20 to 25, the controller is turned on. By default, the speed and direction of the last shutdown setting are saved.

4). Machine lift step: turn on the power, press the power button, press the RUN button to start the motor  
Press the heating button to warm the machine

Shutdown step: Turn off the temperature rise button, turn off the power, wait for the machine to cool down, and automatically power off.

It is forbidden to start the heating before starting the heating. It is forbidden to directly disconnect the drum power supply and stop the drum running.

MTX-68 inverter adjustment use and operation instructions.



## XV. Bill of Material

Roller machine host	1pcs
Open wrench 13MM	1pcs
Hex key 4#/5#/6#/8#/10#	Total 5pcs
Hook wrench	1pcs
Oil filling extension tube	2pcs
Pagoda joint	2pcs
Collector ring copper brush (spare)	8pcs
Rewinding paper tube	3pcs
Instructions	1 pcs

Microtec