

# Pneumatic High Pressure Draw-out Heat Press Manual Model. No.: APD-20/24

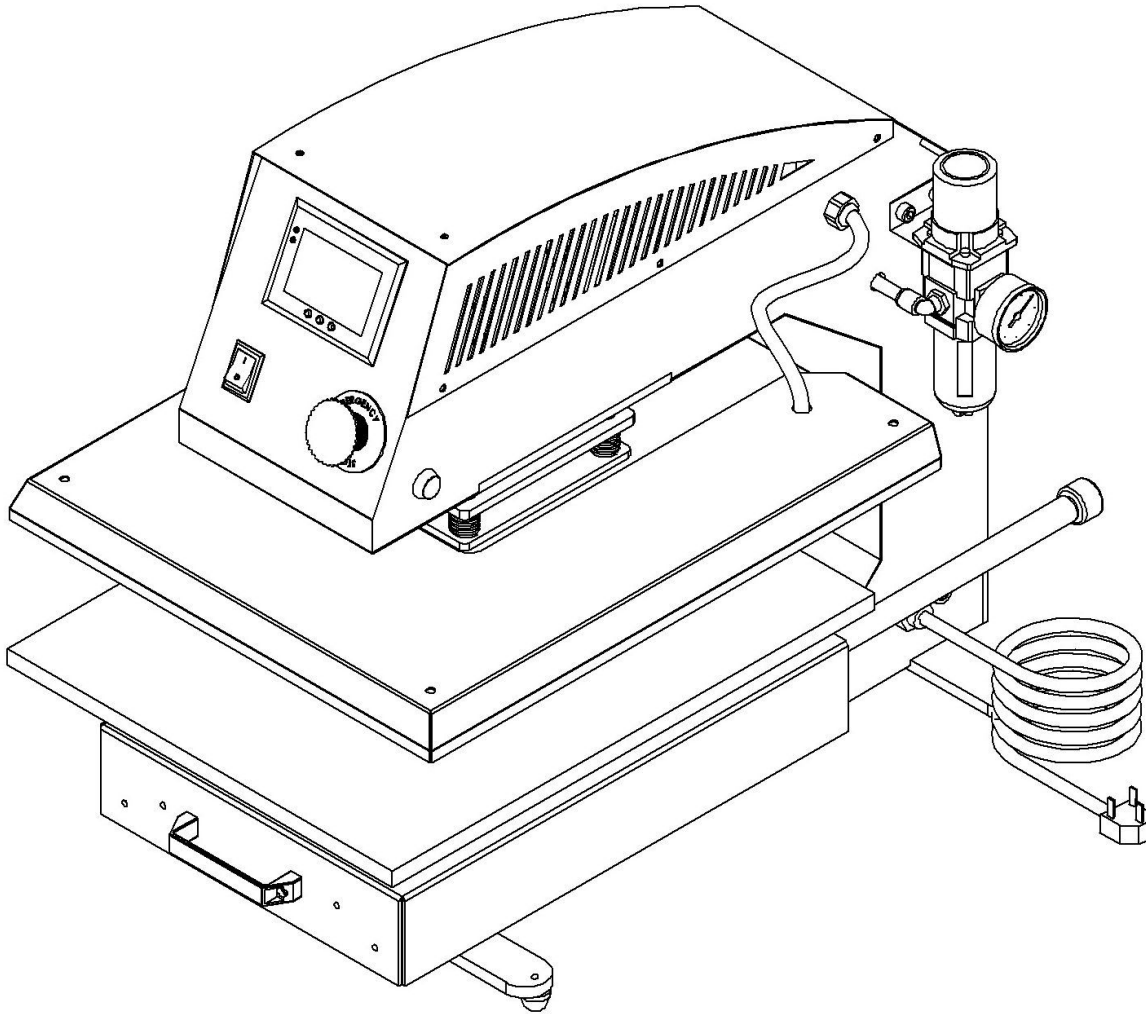

## CONTENTS

I. Assembly Drawing	-----	2
II. Technical Parameters	-----	2
III. Operation Process	-----	3-4
IV. Maintenance	-----	5
V. Trouble Shooting For Transfer Print Quality	-----	5
VI. Circuit Diagram	-----	6
VII. Explosion View	-----	7-8

# I. Assembly Drawing

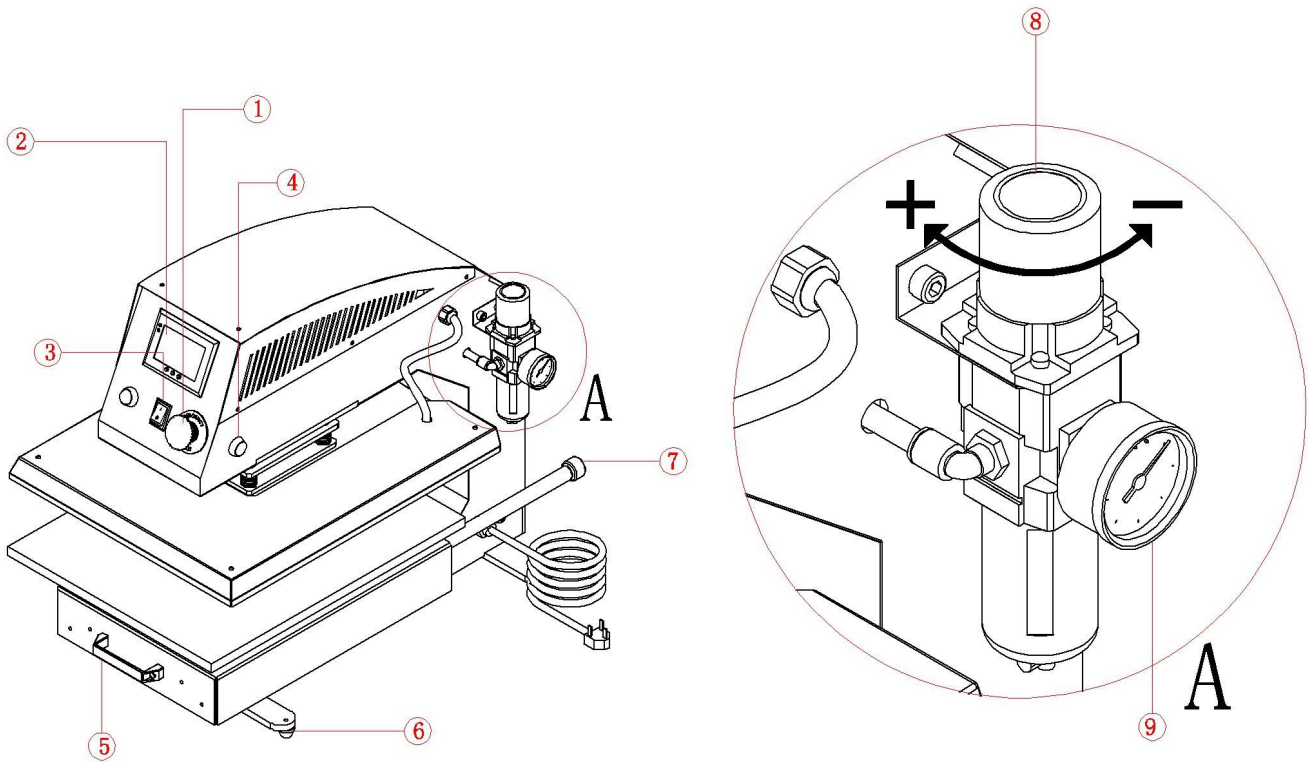

① Emergency Stop Button	② Power Switch	③ GY-06 Digital Controller
④ Start Switch	⑤ Draw-out Handle	⑥ Rubber feet
⑦ Slide Rail	⑧ Air Pressure Adjust Knob	⑨ Air Filter

# II. Technical Parameters

1. Model No.: APD-20/40
2. Machine Dimensions: 810\*410\*625mm
3. Heat Platen Size: 40x50cm/ 40x60cm
4. Printable Articles Max Size: 400\*600\*10mm
5. Voltage: 220V/ Single Phase; 120V/ Single Phase
6. Power: 220V/ 1.8KW ; 110V/ 1.2KW
7. Recommend Setting: 30~280s; 180~210°C.  
 Time Range: 0~999s  
 Maximum Temp: 225°C  
 Heating Tube Power: 1.8KW\* 1pc
8. Packing Size: 500\*700\*700mm/ 900\*500\*720mm.
9. Gross Weight: 62kg/ 76kg ( Wooden Package)

# III. Operation Process

## 1. How to adjust the pressure:

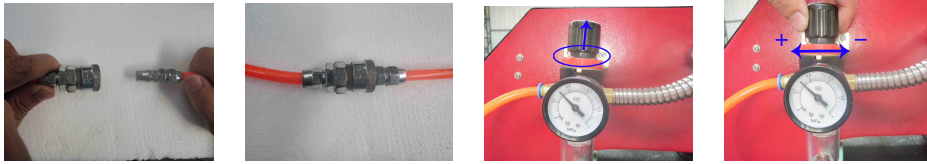

1. Connect the heat press with air compressor or air sources.
2. Lift up the cap of air valve as the picture shown
3. Revolve the cap anticlockwise, the air pressure goes down; contrariwise, the air pressure goes up; when you finish the pressure adjustment, push down the cap.
4. Suggested air pressure is 0.4~0.5Mpa/ 70-80Psi. It depends on the transfer materials.

## 2 Set temperature required

<p>Turn on power switch, temperature light is ON. The digital display shows as above.</p>	<p>Press <b>OK</b> button, the  light is on (C denotes Celsius). Press arrows “△” or “▽” to select “°C” or “°F” (F denotes Fahrenheit) according to your habits.</p>	<p>Press <b>OK</b> button, the temp  light is on. Select with arrows the temperature according to different transfer material (Normally 180°C~200°C) SV: Set temperature PV: Current temperature</p>

## 3 Set time required

<p>Press <b>OK</b> button after temperature setting and the time light is on. Select with arrows the time according to different transfer material. SV: Set temperature PV: Current temperature</p>	<p>Press <b>OK</b> button to operating mode. Counter is “transfer cycle”, from 0~999. Press “Reset” for 5 seconds to make the counter to be “0”.</p>

**Kindly take NOTE:**

1) The P-1 mode is Temperature Difference Calibration Model.

2) The P-2 mode is Heating Mode Setting.



When there is temperature difference between SV (current heating temperature shows on the display screen) and actual Temp of heat platen, please long press  button for 5 seconds to enter the P-1 mode to calibrate.

For example:



When set 200°C, during the heating process, if you find the current heating temperature display shows is 180°C, but the measured actual temperature of heat platen is 170 °C, then please enter P-1 mode and press arrows “▽” to decrease 10°C( adjust the display' Temp value to be same with the actual Temp value.)

Then after adjust, the display will be 170°C. and then the machines will keep heating to 200°C:

We already preset it to 003 before shipment.

That is to say, if your setting temperature is 200°C, it will slow down the heating speed when it heats up to 197°C for a safe purpose.

The suggest value of P-2 mode is 3°C~5°C.

If you want to reset the value, long please press  button for 5 seconds to P-1 mode, and then press  button again to enter into the P-2 mode, and then press arrows “△” or “▽” to set the value you need.

#### 4. Printing methods

Step 1: Make sure the cord is connected well to the wall socket. Place the object (i.e. T-shirt) on press bed, and transfer paper with images facing down the object, adjust pressure to your requirement, and turn on the power.

Step 2: Set the temperature and time required, then temperature starts to rise.

Step 3: When the temperature rise to the setting temperature, the buzzer sends out sounds. Press the two green “Start Button” with both hands, then the heat platen close down automatically (meantime the sounds stop) and starts to transfer.

Step 4: Then the time counter is on, once time is up, the upper heat platen will auto open.

Step 5: Consult the Transfer Paper instructions on whether to peel cold or hot, Here are suggested Pressing time parameter for different transfer paper.

Ink-Jet Transfer Paper (fabric) 14-18 seconds

Laser Copier/Printer Transfer Paper (fabric) 18-25 seconds

Sublimation Transfers (onto Fabrics) 25-30 seconds

Sublimation Transfers (onto FR-Plastic/Woods) 60-70 seconds

#### **4. Recommendations:**

1) Ceramic tile transfer: (Mugs & Plates transfer is similar)

Set temperature: 180°C.

Set time: 15 seconds

2) T-shirt transfer:

Set temperature: 180°C.

Set time: (chemical fiber use for sublimation transfer paper: 30-50 seconds; pure cotton use for T-shirt transfer paper: 10-20 seconds)

3) Aluminum sheet transfer:

Set temperature: 180°C

Set time: 45 seconds

#### **Emergency:**

If any emergency happens, please press the red emergency stop button. After settled the emergency, please turn the button clockwise and let it resume original status, and the machine will also resume working status.

#### **NOTE:**

1. Please switch off the machine power control valve if there is any problem.
2. The suitable air pressure is 0.4-0.5Mpa or 75-80Psi, neither too high (too high air pressure can destroy the machine), nor too low (lower air pressure can't let the heat platen work smoothly.)
3. Suggestion to power off for 1-2 hours after continuous working for 6-8 hours.

#### **▲. When you finish the transfer process, there are two important matters need attention.**

4. Please don't shut down the power immediately, the heat platen is very hot now after long time working, please press "OK" button after you finish the last heat transfer process, then the heat platen will stop heating, but the fan in electronic box is still working, it helps cooling the hot heat platen. Please keep power for around 20-30 minutes after you finish the transfer process.
5. Please don't shut down the air pump immediately, the heat platen is very hot now after long time working, if you shut down the air pump, the hot heat platen will close and depress to under platen, it would burn the cotton pad. Please keep air pump works for around 20-30 minutes after you finish the transfer process.

## IV. Maintenance

### 1. No action after turn on the machine

- 1). Check the plug whether it connects well or whether it is broken.
- 2). Check the power switch or digital controller whether it is broken.
- 3). Check the fuse whether it has been burnt out.
- 4). Indicating light is on, but no display on screen, check the 5 cable of Railway transformer. If it's loosening, showing the problem is poor connection. If they connects well, showing that the Transformer is faulty.

### 2. The display screen are working well, but no temperature increasing on the heat platen.

- 1). Check whether the thermocouple of the heat platen touches well. If the thermocouple is loose, the display will show 255 and machine keeps beeping.
- 2). Check if the indicating light of solid-state relay is on, if not, check if the relay or digital controller is broken.
- 3). If you already changed the new solid-state relay but the heat platen still can't heating up, check if the heat platen is faulty or the heat platen's power cable is loose, need to change by new heat platen.

### 3. The heat platen works well, but suddenly the display screen show 255°C.

- 1). Check whether the thermocouple of the heat platen touches well.
- 2). If the thermocouple touches well but still shows 255°C, then it is faulty.

### 4. The machine is heating during 0~180°C, but display number jumps to above 200°C or 300°C suddenly, or the numbers on display jumps irregularly.

- 1). Check whether the thermocouple of the heat platen touches well.
- 2). If the thermocouple is good, It shows that the program of digital controller is broken, which namely IC or is broken, need to change by new controller.

### 5. The temperature is out of control: Set 180°C, but the actual temperature is above 200°C.

- 1). It means the solid-state relay is broken, out of control, need to change the relay.
- 2). Or the digital controller is faulty and it keeps conveying electric to relay, need to change controller.

### 6. The setting temp and time becomes abnormal after exchange the heat platen

- 1). Please reset the temp and time according the operation process manual.

### 7. Other notice

- 1). In order to prolong the machine service life, please add the lubrication oil regularly on the joints.
- 2). In order to keep the heat platen's good transfer effect, you need to protect the heat platen carefully whenever you are using it or not.
- 3). Please keep the machine in dry place.
- 4). If you are not able to solve the electrical parts problem, please kindly contact the supplier and get technical support.

## V. Trouble shooting for transfer print quality

1. If the print color is pale: the temperature is too low / the pressure is not correct / or not pressed long enough.
2. If the print color is too brown or the transfer paper is almost burnt: reduce the setting temperature
2. If the print is blurring: too much transfer time causes proliferation.
3. If print color is different/ partial transfer effect is not good enough: the pressure is not enough / or not pressed long enough / or poor quality transfer paper.
4. If transfer paper stick to the object after transfer: the temperature is too high/ or poor quality printing ink.



# VI. Circuit Diagram

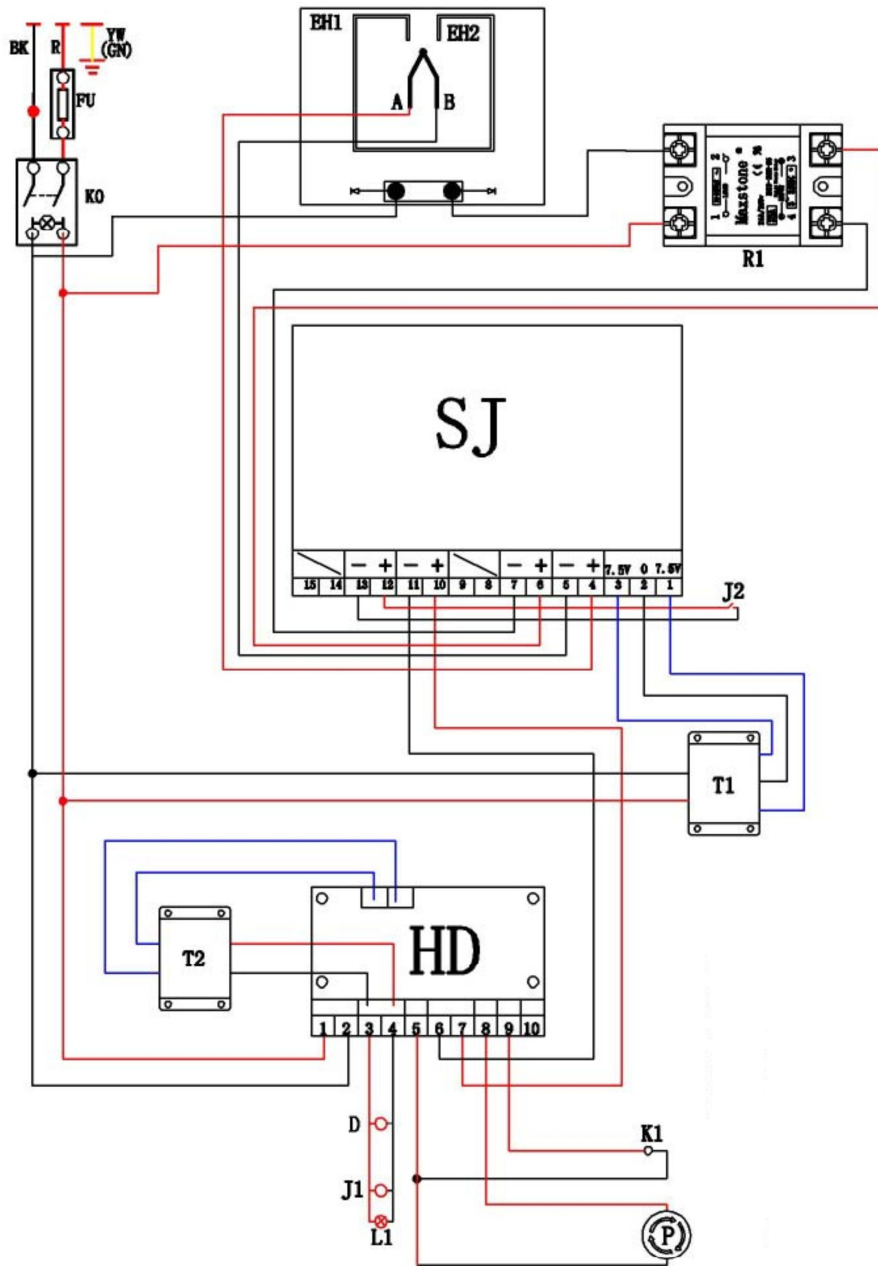

KO: Power switch

SJ: GY-04 Digital Controller

J2: Intermediate Relay Contacts

EH1-EH2: Heating Pipe

P: Emergency Stop Button

K1: Start Switch

HD: Pneumatic Controller

L1: Indicator Light

A-B: Thermocouple

FU: Fuse(240V/15A, 120V/20A)

J1: Industrial Relay

D: Pneumatic Valve

T1(T2): AC/DC Transformer

## VII. Explosion View

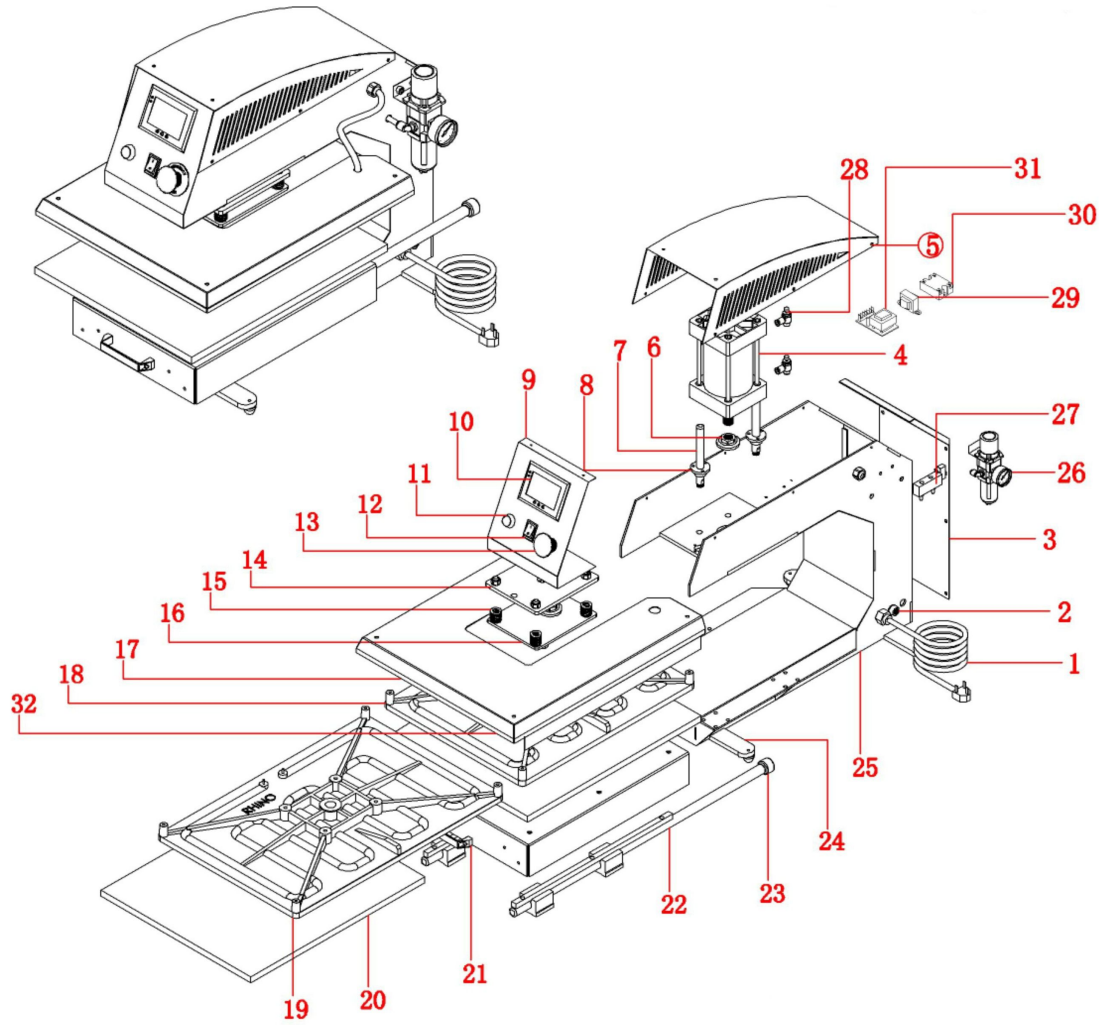



No.	Part Name	Qty
1	Power Cord	1
2	Fuse	1
3	Back Cover	1
4	Air Cylinder	1
5	Electronic Cover	1
6	Lock Nut	1
7	Fixing Pillar	2
8	Washer	2
9	Controller Cover	1
10	GY-04 Digital Controller	1
11	Start Switch	1
12	Power Switch	1
13	Emergency Stop Button	1
14	Adaptor Plate	1
15	Spring	4

16	Adaptor Plate	1
17	Anti-scald protect metal cover	1
18	Heat Platen 40x50 cm	1
19	Heat Platen 40x60 cm	1
20	Under Plate	1
21	Draw-out Handle	1
22	Slide Rail	2
23	Slide Rail Mat	2
24	Rubber Feet	2
25	Machine Frame	1
26	Air Valve	1
27	Electromagnet Valve	1
28	Air Hose Connector	2
29	Transformer	1
30	Solid-state Relay	1
31	Electromagnetic Driver Board	1